



# roburtrucks

## Building customer partnerships

As a leading supplier of bespoke materials handling equipment for any application from 300kg to 30,000kg, Roburtrucks has total control over the design and manufacturing process. Bringing decades of experience to customer partnerships, our focus on research and development enables Roburtrucks to continually innovate solutions to customer challenges.

Every machine is expertly engineered to meet the required application and is built to the most rigorous safety standards using optimum grade stainless steel, and other high durability construction materials.

Roburtrucks delivers tangible asset value to client businesses.

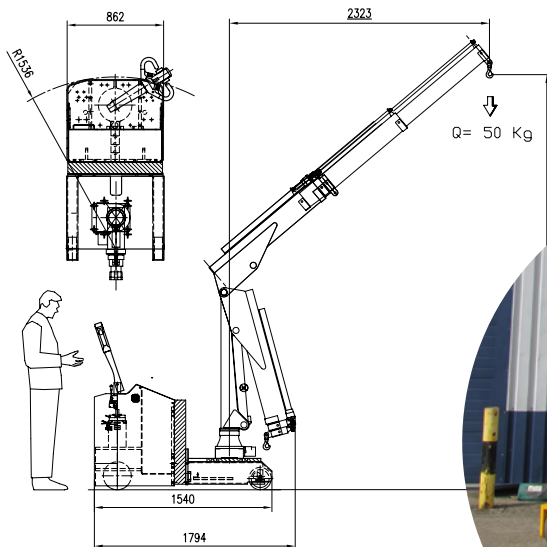



## Our process from enquiry to delivery



Roburtrucks bespoke solutions can overcome any material handling challenge for any application. To arrange a free quote please call 0800 298 2980 or email [sales@roburtrucks.co.uk](mailto:sales@roburtrucks.co.uk)

➤ [sales@roburtrucks.co.uk](mailto:sales@roburtrucks.co.uk)

➤ [www.roburtrucks.co.uk](http://www.roburtrucks.co.uk)

➤ 0800 298 2980